

INDOOR/OUTDOOR CABLE

CORESPAN™ INDOOR/OUTDOOR LSZH RISER CABLE

Fibre Systems CoreSpan™ Indoor/Outdoor LSZH distribution cables are designed for campus links between buildings where runs are short enough for installers to benefit from the lower termination costs of tight-buffered cable. For indoor use, the cable has an LSZH sheath. For outdoor use, it includes an outer jacket with UV stabilisation for sun exposure and anti-fungal protection for underground installations.

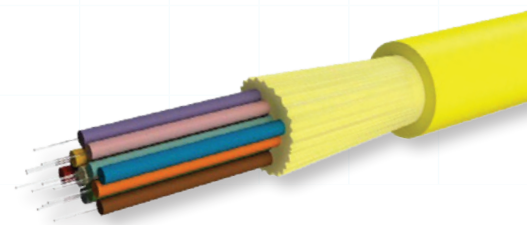

Technical Data

NUMBER OF FIBRES		6	12	24
Tight buffer diametre	µm		900 ± 50	
Cable nominal diametre	mm	5.1	6.2	8.1
Cable nominal weight	kg/km	24	38	61
Max. installation tension	kN	60 (Short term)		
Max. crush resistance	kN/100mm	At Installation 20x Cable OD		
Min. bending radius	mm	At Operation 10x Cable OD		
Temperature range	°C	Installation 0 -> +50 Transport & Storage -10 -> +60 Operation 0 -> +70		

INDOOR/OUTDOOR CABLE

PARAMETRE	TEST METHOD	TEST CONDITIONS	ACCEPTANCE CRITERIA*
Tensile strength	IEC 60794-1-2-E1	Load: As per cable maximum tensile strength in table above	After 30 minutes the maximum strain on the fibre should not exceed 0.5% and no attenuation increase greater than 0.1 dB occurs
Crush	IEC 60794-1-2-E3	Short time: 10 min Load: As per maximum crush resistance in table above Number of positions: 3 adjacent sections (ensuring one over tube and one over lay reversal)	No damage to the sheath or to the core structure and no attenuation increase greater than 0.1 dB occurs
Torsion	IEC 60794-1-2-E7	Sample length: 1m Tension: As per table 1 of specification Rotation: a) 180° clockwise, b) return to starting position c) 180° anticlockwise d) return to starting position. Four movements constitute one cycle) Complete 10 cycles (a to d) in one minute maximum	During the final tenth cycle at a), c) and after completion (no rotation) check transmitting fibres. No fibre breaks, no damage to the sheath or to the core structure and no attenuation increase greater than 0.1 dB occurs.
Bend	IEC 60794-1-2-E11	Mandrel radius: As per minimum bend radius at no load in table above Bend: 360° (1 turn)	No attenuation increase greater than 0.1 dB occurs
Bend under tension	Concurrent to tensile test IEC60794-1-2-E18	Mandrel radius: As per minimum bend radius at full load in table above Bend: 360° (1 turn)	After 1 minute no fibre breaks, no damage to the sheath or to the core structure and no attenuation increase greater than 0.1 dB occurs from no load to full load
Temperature cycling	IEC 60794-1-2-F1	Sample length: 1000m (minimum) Temperature range: from 0°C to +70°C	There should be no average attenuation increase at the temperature extremes when compared to the attenuation at ambient temperature. No individual fibre should measure an attenuation greater than 0.15dB/km
Water penetration	IEC 60794-1-2-F5B	Sample length: 3m Water height: 1m	No water leakage after 24 hours

* All optical measurements for singlemode fibres performed at 1550nm.

Identification

NUMBER	1	2	3	4	5	6	7	8	9	10	11	12
Colour	Blue	Orange	Green	Brown	Grey	White	Red	Black	Yellow	Violet	Pink	Aqua
Number	13	14	15	16	17	18	19	20	21	22	23	24
Colour	Blue / Black	Orange / Black	Green / Black	Brown / Black	Grey / Black	White / Black	Red / Black	Black / White	Yellow / Black	Violet / Black	Pink / Black	Aqua / Black

TIA-598-C, colour-coded tight buffer



CONTACT: Call: +61 2 8553 0600 Email: sales@fibresystems.com.au www.fibresystems.com.au

Fibre Systems is an Australian-owned provider of ruggedised, high-performance fibre optic cable systems.
© 2026, Fibre Systems, all rights reserved. Specifications are subject to change without notice.

INDOOR/OUTDOOR CABLE

Sheath Marking

CORESPAN FIBRE CABLE INDOOR / OUTDOOR RISER LSZH **F G652D CS-IORL-***-**-** MMYYY Drum Number 0000M >>|<< 0000M

Fibre Specifications

CORE SIZE	ISO/IEC	MAX. ATTENUATION (DB/KM)			OVERFILL LAUNCH MIN. BANDWIDTH (MHZ•KM)	G-ETHERNET MAX. LINK DISTANCE (METRES)		10G-ETHERNET MAX. LINK DISTANCE (METRES)		
		850 NM	(MM) 1300 NM (SM) 1310 NM	1550 NM	850 NM	(MM) 1300 NM (SM) 1310 NM	850 NM	(MM) 1300 NM (SM) 1310 NM	850 NM	(MM) 1300 NM (SM) 1310 NM
62.5µm	OM1	3.0	1.2	N/A	200	500	300	500	—	—
50µm	OM4	3.0	1.2	N/A	3.500	500	1.040	550	550	—
9µm ITU G.652.D/ G.657.A1	OS1/ OS2	N/A	0.4	0.3	N/A	N/A	N/A	5.000	N/A	10.000

Qualifications

GOVERNING BODY	STANDARDS CODE	COMPONENT
AS/CA	S008	Cable
IEC	60794	Cable
Standards Australia	AS 1049	Materials
IEC	60793	Fibre
ITU-T	G.652.D / G.657.A1 / G.651.1	Fibre
TIA	598-D	Fibre
RoHS	EU Directive 2015/863	Cable
AS/NZS IEC	60332.1	Cable



CONTACT: Call: +61 2 8553 0600 Email: sales@fibresystems.com.au www.fibresystems.com.au

Fibre Systems is an Australian-owned provider of ruggedised, high-performance fibre optic cable systems.
© 2026, Fibre Systems, all rights reserved. Specifications are subject to change without notice.

INDOOR/OUTDOOR CABLE

Ordering Information

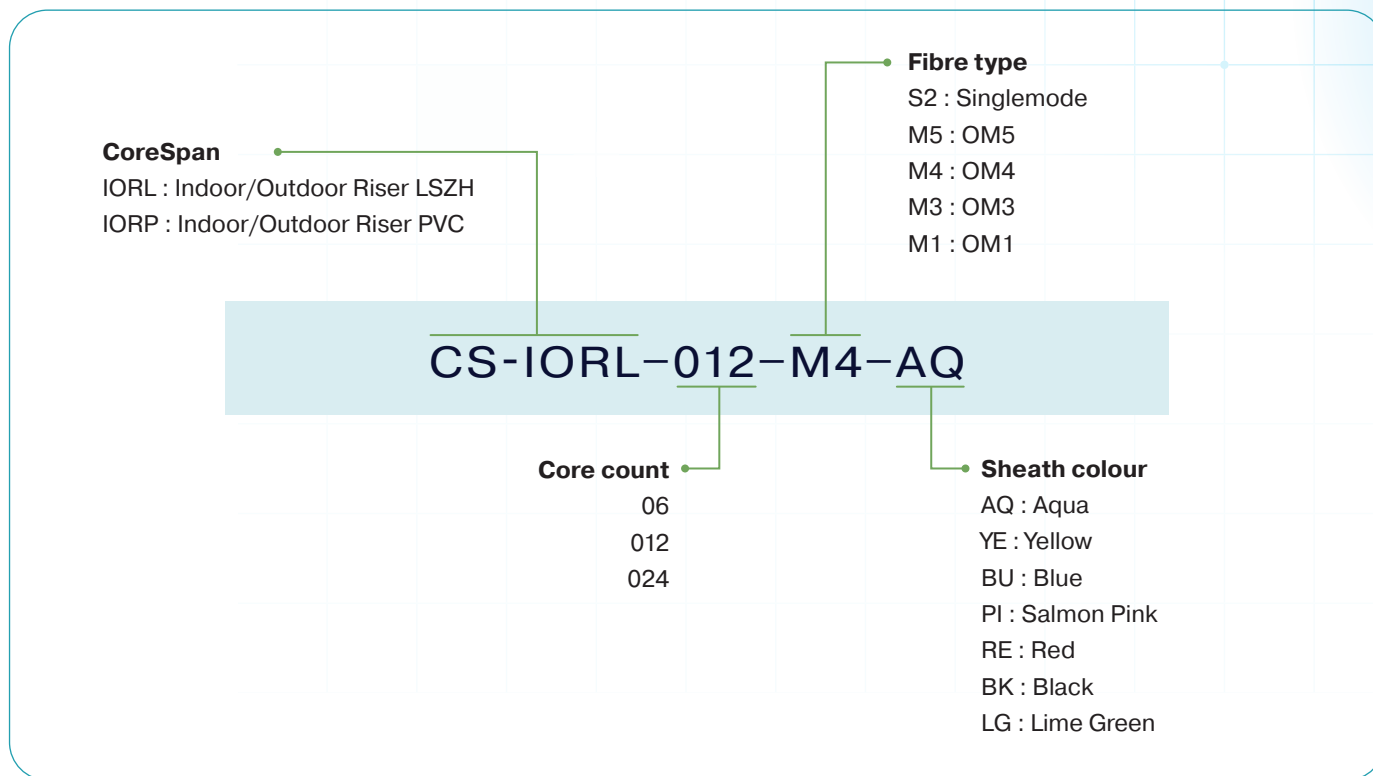

We reserve the right to make technical modifications, typographical errors and mistakes. Transfer to third party only by authority of Fibre Systems Pty Ltd or its affiliates. Note: Fibre Systems guarantees that the delivery items contained in this data sheet are measured exclusively according to the concrete agreements relating to the properties, features and performance characteristics of the respective delivery item concluded in writing between Fibre Systems and the orderer. Illustrations and specifications in data sheets, other information material, provided to the orderer by Fibre Systems, as well as product descriptions are only legally binding, if they are explicitly identified as binding specifications. Under no circumstances should specifications of this type be taken as guarantees of the delivery item corresponding to a particular quality. Guarantees of quality of this type must be explicitly agreed in writing. Fibre Systems reserves the right to modify the data sheet contents at any time.



CONTACT:

Unit 4 / 277 Lane Cove Road, Macquarie Park, NSW 2113
Call: +61 2 8553 0600 Email: sales@fibresystems.com.au
www.fibresystems.com.au

040 Revision 01, 06.26



Fibre Systems is an Australian-owned provider of ruggedised, high-performance fibre optic cable systems.
© 2026, Fibre Systems, all rights reserved. Specifications are subject to change without notice.